

separators  
conveyor accessories  
rubber screens  
engineered process

## Linapump IIIr Centrifugal Slurry Pumps



engineered process  
cyclone  
materials handling  
hose



systems separators  
conveyor accessories  
rubber  
alves

# LINATEX

There is no equivalent

**Introduction**

The Linapump IIIr is the latest generation of our successful abrasion/corrosion resistant slurry handling pump and combines effective gland sealing with good hydraulic efficiency.

**Impeller**

Thick, hydrodynamically efficient Linatex rubber over steel reinforcing gives optimum performance

**Outer Casing**

Rigid casing design facilitates ease of field liner

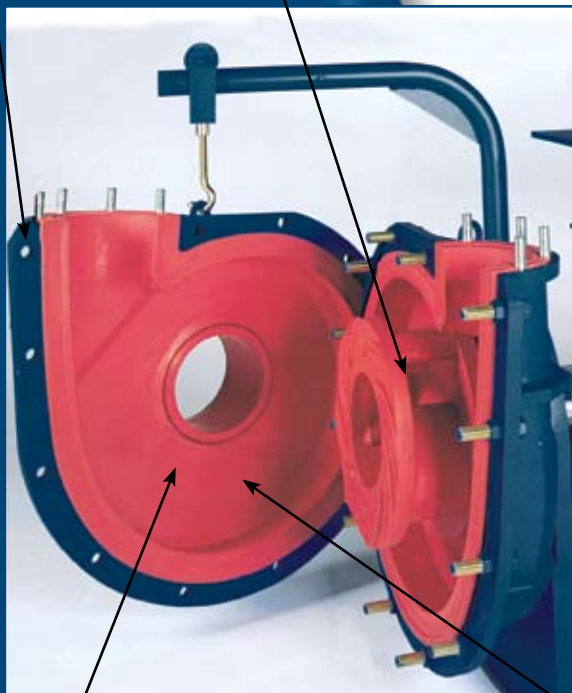

**Suction Bush Liner**

Simple, easy to replace high quality Linatex rubber bush on 150 x 125 upwards

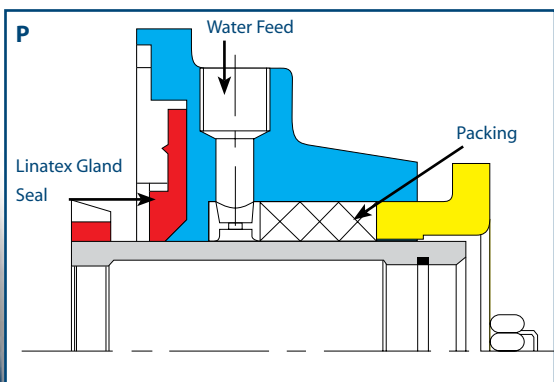
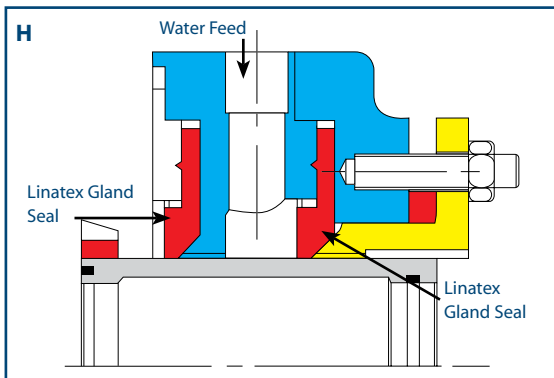
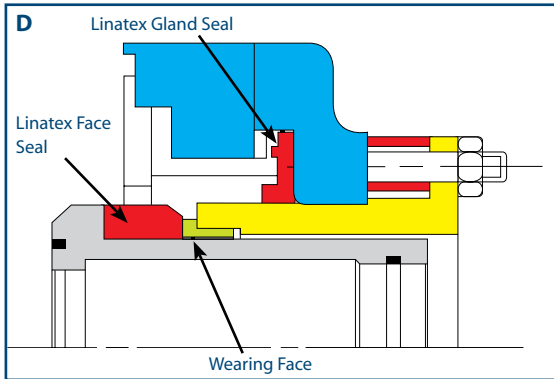

**Casing Liners**

Field-proven Linatex abrasion and corrosion-resistant rubber liners moulded over steel reinforcement give maximum wear life. Alternative rubber compounds available for pumping oil, chemicals, food products and higher temperature slurries. Bolt in design facilitates simple site replacement.

- Increased wear life with Linatex rubber
- Thicker rubber at recognised areas of wear
- Unique, reliable energy efficient gland sealing system
- Simple mechanical design for easy maintenance
- Low cost gland parts
- Low energy consumption

**Results in lowest total whole life operating cost.**

**‘D’ - Dry Gland**

Unlike conventional mechanical seals, the Linatex dry gland has a stationary hard wearing face flexibly held against the Linatex rubber rotating ring. Any particle getting between the faces is absorbed into the Linatex rubber. This seal absorbs little energy and requires no external lubrication. It is particularly recommended where the use of gland water is undesirable.

**‘H’ - Hydrostatic Gland**

With lowest maintenance and longest life, the unique Linatex rubber gland seal is designed to deflect inwards to provide an effective seal. A clean water supply of 0.2 bar above pump discharge pressure is required with a flow of between 0.04 and 0.15 litres per second, depending on pump size.

**‘P’ - Packed Gland**

Sealing is obtained by compressing the gland packing rings onto the shaft sleeve. The gland offers the capacity to seal the pump even at high pressures, for instance in series pumping. A clean water feed or grease is essential to lubricate the packing to sleeve interface to provide additional cooling.



**Gland Options**

Three interchangeable gland designs are available to suit operator preference and site conditions.

**Drive Positions**

Overhead & horizontal Vee-belt, Direct coupled and Z-drive. Maximum flexibility to suit each installation.

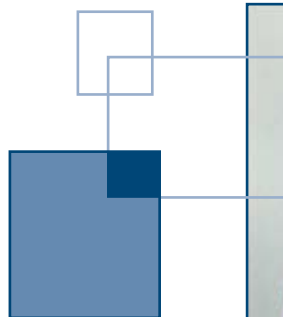

**Bearing & Shaft Assembly**

Fully enclosed, heavy duty assembly gives long service life and allows easy removal for clean bench inspection and maintenance



**Pedestal**

Construction provides rigid mounting for pump assemblies.

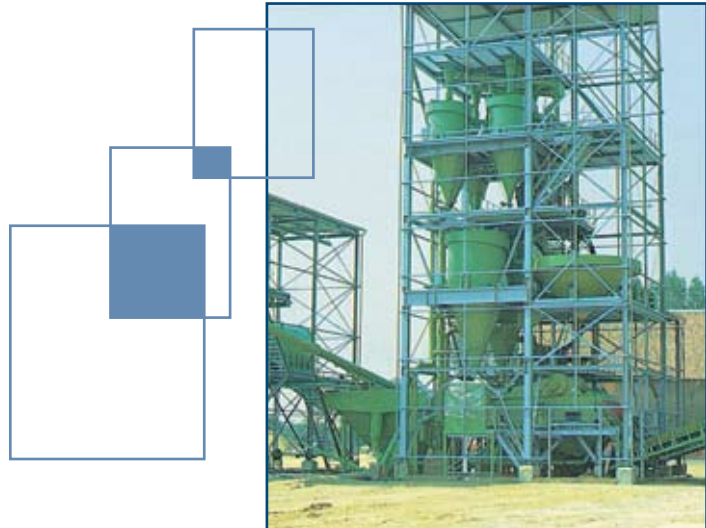

### **Total Service**

From design to installation and beyond, Linatex engineers are available to give advice on your slurry pumping needs and problems. We've been in the business of designing and manufacturing pumps for over 60 years and our collective experience in abrasive slurry handling is second to none.

The Linapump IIIr range has been designed to offer a wide choice of pump sizes to suit most slurry pumping applications. The selection chart below demonstrates the coverage of Linapump IIIr performance over a range of flow rates and total heads. A standard questionnaire is available to ensure that the most complex installation, as well as the more straightforward pumping application, receives individual consideration.

Linatex can also advise on the ancillary components within the pumping system. The provision of abrasion resistant low head loss valves, sumps, priming devices and flexible bends incorporating Linatex linings for trouble-free life, are an important aspect of ensuring a totally successful pump installation.

### **Linapump IIIr Selection**

The importance of selecting the correct size and type of Linatex slurry pump cannot be overstated. Selection is based on analysing a number of factors which, when considered in total, determine the pump's performance for a given installation and duty.

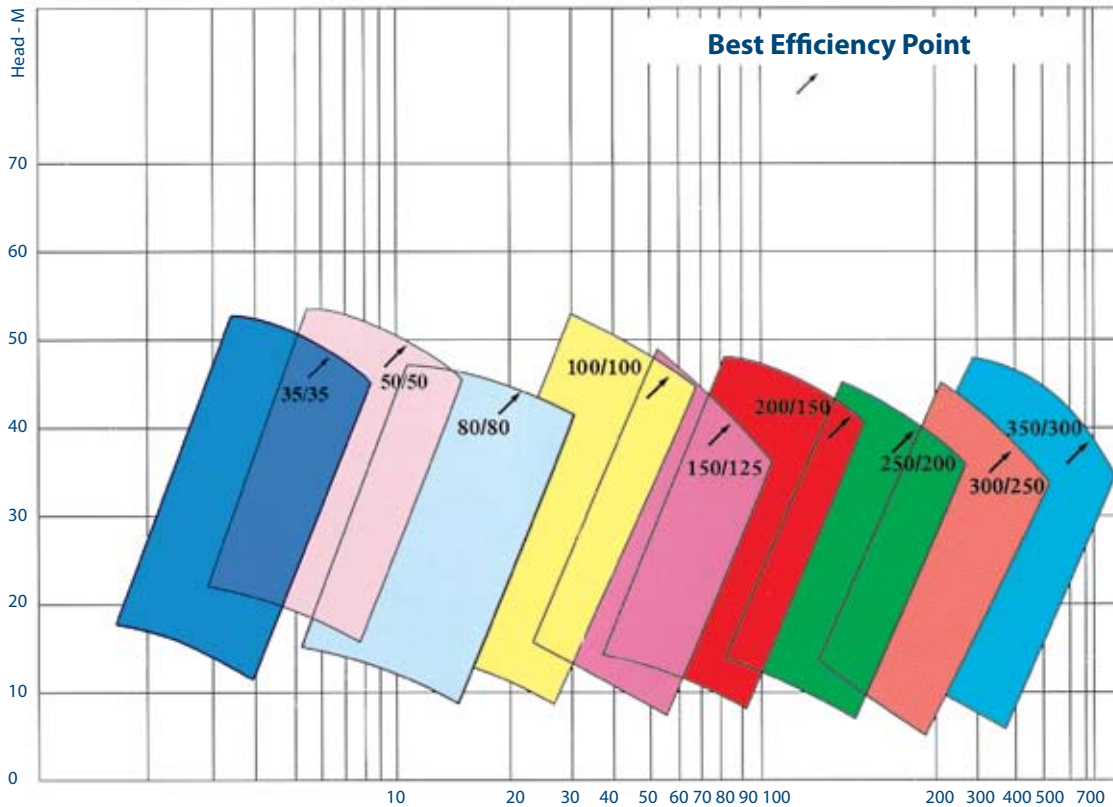

**Linapump IIIr  
Preliminary Selection Chart**

Flow 1/s

The principal factors which affect the pumpability of solids in suspension are:

- The amount of dry solids and their density.
- The density of the carrying liquid.
- The maximum particle size and representative size distribution.
- The shape of the particle.
- The discharge pressure.

In addition, other parameters such as pipe layout, suction conditions and friction losses relating to pipework and fittings must also be considered in the calculation.

Linatex can advise on these aspects of your slurry system.

**Pumptec: Computer Aided Support**

To complement and facilitate optimum selection of your slurry system, Linatex has developed "Pumptec." This unique computer programme, available for use on a personal computer, allows the operator to:

- Calculate the pump duty and select a pump and drive.
- Analyse the effects of changing slurry density.
- Calculate the pump de-rating for slurry mixture.
- Calculate setting velocities of various slurries and select pipe sizes.
- Calculate pipeline frictional losses in various pipe materials and pipe fittings.

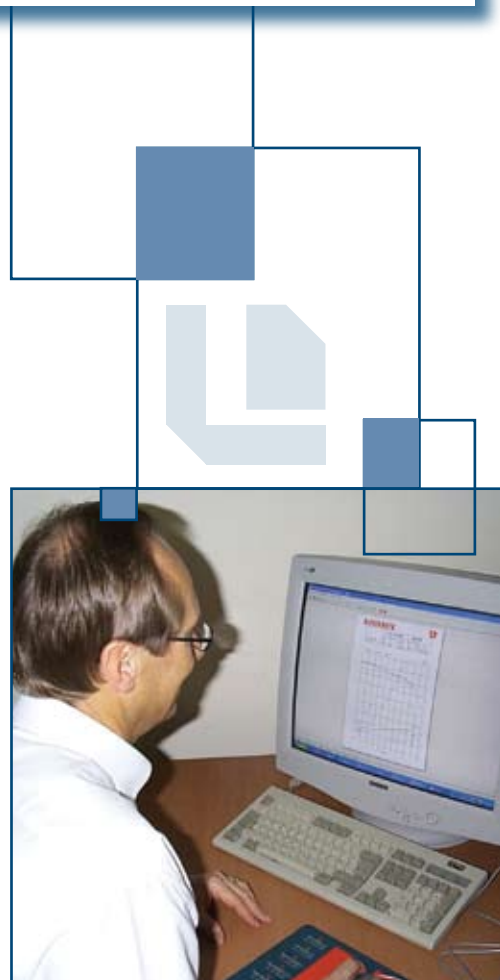

Equally suitable for handling abrasive slurries or combinations of abrasives and corrosive solutions, Linatex pumps will solve pumping problems outside the scope of metal and other types of pumps.

The following list gives but a few of the many duties for which Linatex pumps have been used.



### - Sand plants

Feeding sand and water to all types of classification and dewatering plants; effluent water transfer duties.

### - Coal preparation plants

For dense medium circuits; feeding hydrocyclones; filtrate pumping; handling the underflow from thickeners; disposal of washery effluent, etc.

### - Chemical works

Linatex pumps, by virtue of their rubber linings, are suitable for pumping many chemical solutions, acid or alkaline, at moderate temperatures and for the disposal of effluent.

### - Cement manufacture

Slurry feed to tube mill circuits; thickener feed and underflow; flotation plant circuits.

### - Metalliferous mining

Mill circuits; feeding hydrocyclones; cyanide plant filter residues; concentrates; tailings disposal and other pulp and slurry handling duties.

### - Irrigation schemes and Dredging

Silt removal in dams and canal sand traps.

### - Paper mills

China clay slurries; paper stock; effluent disposal.

### - Steel works

Pickling acid distribution circuits in plate and wire de-scaling plants.

### - Power stations

Boiler house ash disposal; de-scaling plants.

### - China clay works

Feeding slurry to hydrocyclones and for general use in the preparation of china clay.

### - Glass works

Feeding polishing media; sand plants; handling effluent.

### - Water Treatment

Feeding sand and water to all types of classification and dewatering plant.

### - Vegetable washing

Feeding sand and dirty water to all types of classification and dewatering plants, effluent water transfer.



**Design Specifications and Options**

Linapump IIIr standard casing is designed for a maximum working pressure of 10 bar. Higher pressure casings are available for series pumping. Please contact Linatex for higher pressure applications.

Suction and discharge flanges are universal and available in metric BS4504 and ASA150 drilling patterns as standard. Other drilling patterns are available to order. Orientation of discharge to 4 positions according to installation requirements.

The Linapump IIIr range of pumps is designed and manufactured in accordance with appropriate International Quality Standards, such as ISO9000.

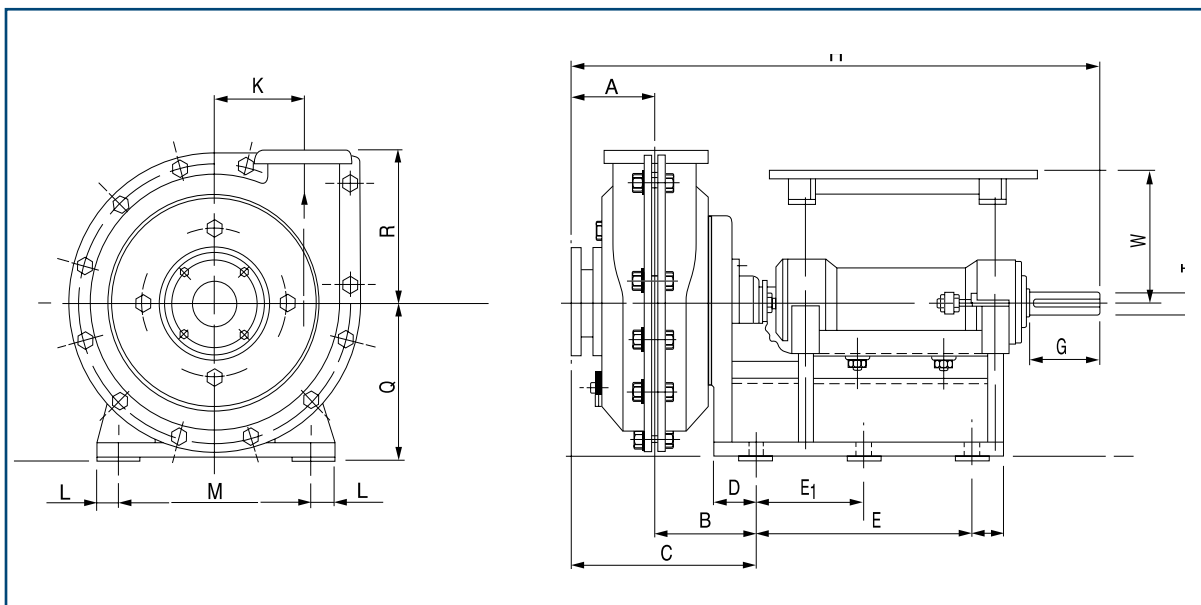

**End elevation**

**Side elevation**

PUMP SIZE (mm)	MASS (kg)	Dimensions in mm																
		A	B	C	D	E	E1	F	G	H	K	L	M	Q	R	T	W	W
35 x 35	142	87	137	224	49.5	310	-	46	70	725	111	20	285	250	216	40	165	220
50 x 50	156	92.5	132	224.5	49.5	310	-	46	70	725	120.5	20	285	250	241	40	165	220
80 x 80	326	120	180	300	65	355	-	50	120	915	168	30	360	300	295	45	250	310
100 x 100	440	132	169	301	57	460	-	40	127	998.5	184	30	400	336	324	60	272	372
150 x 125	608	211	234	445	100	479	-	100	189	1286	210	30	480	390	368	65	340	440
200 x 150	736	217.5	223	440.5	90	468	-	66	174	1312.5	222	35	490	428	394	70	345	445
250 x 200	1250	309	270	579	108	660	330	76	200	1600	321	40	660	550	406	90	430	585
300 x 250	1956	317.5	285	602.5	70	640	320	70	200	1697.5	368	40	750	600	483	100	-	-
350 x 300		322	329	651	90	660	330	93	230	1752	441	40	770	650	560	110	-	-

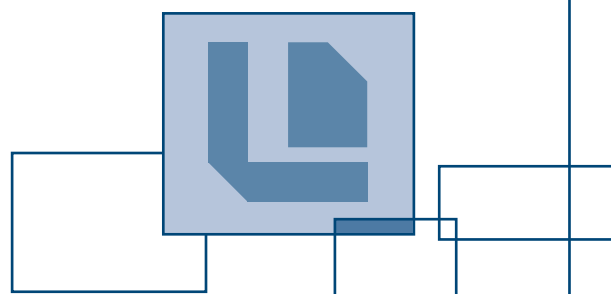

## Linatex Asia

---

### LINATEX MALAYSIA

#### Commercial Division – ASIA

Linatex Rubber Products

6 Mile Jalan Ipoh, 68100 Batu Caves,  
Selayang, Selangor, Darul Ehsan,  
Malaysia

Ph: 0011 60 3 6251 2195

Fax: 0015 60 3 6255 2173

### LINATEX CHINA

Room 3101 New Town Centre

No 83 Loushanguan Road

Shanghai 200336

People's Republic of China

Ph: 0011 1 480 733 2391

Fax: 0015 1 480 733 2918

Mobile: 0011 1 602 418 9848

## Linatex North America

---

### TENNESSEE - HEAD OFFICE

1550 Airport Road, PO Box 899

Gallatin Tennessee 37066, USA

Phone: 0011 1 615 230 2100

Fax: 0015 1 615 230 2109

### ARIZONA

1616 East Main Street, #207C,

Mesa, Arizona 85203, USA

Phone: 0011 1 480 733 2391

Fax: 0015 1 480 733 2918

## Linatex South America

---

### CHILE

Santa Catalina de Chena 850

Parque Industrial Estrella Del Sur

San Bernardo, Santiago, Chile

Phone: +56 2 447 9400

Fax: +56 2 447 9368

### SOUTH AFRICA

Linatex Africa (Pty) Ltd

PO Box 123793, or 5 Fuchs Street, Alrode 1451,

Gauteng, South Africa

Phone: 0011 27 11 617 4800

Fax: 0015 27 11 908 1644 Head Office

Fax: 0015 27 11 908 2130 Process Equip.

Fax: 0015 27 11 908 5518 Rubber/Pumps

## Linatex Europe

---

### UNITED KINGDOM

Wilkinson House, Blackbushe Park,

Galway Road, Yateley

Hampshire GU46 6GE, England

Phone: 0011 44 1252 743000

Fax: 0015 44 1252 743046

## Linatex Australia

---

### MELBOURNE - HEAD OFFICE

Suite 7, 61-63 Camberwell Road

Hawthorn East, VIC 3123

Phone: 03 9834 7400

Fax: 03 9834 7405

### DANDENONG

23 Quality Drive

Dandenong, VIC 3175

Phone: 03 9706 6568

Fax: 03 9706 6575

### TOWNSVILLE

Lot 3, 694 Ingham Road

Mt. St. John, QLD 4814

Phone: 07 4758 6100

Fax: 07 4758 6111

### MT ISA

26 Richardson Road

Mt Isa, QLD 4825

Phone: 07 4743 2805

Fax: 07 4743 7209

### DARWIN

2/15 Graffin Crescent

Winnellie, NT 0820

Phone: 08 8984 4931

Fax: 08 8984 3032

### PERTH

30-36 Wittenberg Drive

Canning Vale, WA 6155

Phone: 08 9256 8300

Fax: 08 9265 8305

### KALGOORLIE

216 Dugan Street

Kalgoorlie, WA 6430

Phone: 08 9021 0266

Fax: 08 9021 0277

# LINATEX

There is no equivalent

[www.linatex.com](http://www.linatex.com)

All product design, dimensional and general information contained in this catalogue is subject to change without notice. Linatex strongly recommend consultation with Linatex staff before purchase to ensure the correct equipment is chosen. All process equipment should be used for its intended designed purpose only. Failure to follow procedures for selection, installation, care, maintenance, storage and handling may result in premature failure and may result in damage to property and/or serious injury. Linatex standard terms and conditions of sale will apply.